



BMS-10P Stud Welder

Operating Instructions



GB: English Version

Read these operating instructions before starting any work!



Doc.ID: **P00297**

Date of issue: 02.2021

www.soyer.de

Operating Instructions

BMS-10P Stud Welder

Serial number *

BMS-10P Stud Welder _____

Please enter the serial number here, so that the data is immediately available if you need service support.

Order No.	Code designation	Note
P01063	BMS-10P	Mains voltage 230 V (OPTION 115 V *1) with capacitance change-over 33,000 / 99,000 µF
*1 The BMS-10P stud welder is suitable for operation with 115 V or 230 V. The current mains voltage is indicated on the type plate.		



Thank you!

Congratulations on purchasing the BMS-10P SOYER stud welder. You have made an excellent choice. Your BMS-10P SOYER stud welder was specially developed for the high-speed fastening of SOYER weld studs in compliance with **DIN EN ISO 13918** on metallic, weldable workpieces.

Our devices have been tested and proven according to current European and national guidelines on health and safety. Proof of conformity has been established and the manufacturer is in possession of the corresponding documents.



FOR YOUR SAFETY

Read all of these operating instructions prior to start-up. Please follow all safety precautions as well as all chapters of these operating instructions before starting to weld. Non-compliance with the safety precautions can result in serious personal injuries or death.

SOYER® is a registered trade mark of Heinz Soyer Bolzenschweißtechnik GmbH.

It is prohibited to distribute or reprint this document. It is also prohibited to exploit or disclose its contents unless permission has been expressly granted. Non-compliance with this regulation will lead to compensation for damages. All rights reserved, particularly in the case of a patent grant or a GM registration.

We have verified that the contents of this pamphlet correspond to the hard- and software described. Deviations, however, cannot be excluded so that we cannot warrant for absolute compliance. The illustrations contained in this instruction manual can vary in some details from your product. This, however, has no influence on the handling of the machine

The data in this documentation is verified regularly and any necessary corrections incorporated in future impressions. Any suggestions for improvement are appreciated.

Date of issue: January 01, 1998
Revision: (Update Declaration of conformity: 2021-02)
© Heinz Soyer Bolzenschweißtechnik GmbH 2013 · All rights reserved

Printed in the Federal Republic of Germany

**Heinz Soyer Bolzenschweißtechnik GmbH
Inninger Straße 14
82237 Wörthsee**

CE Declaration of Conformity

We herewith declare that the machine described in the following and the version available on the market correspond in design and construction to the safety and health requirements of the listed guidelines and standards. Any unauthorised modification to this machine automatically annuls this declaration.

Designation of machine	:	<u>Stud welding device</u>
Machine type	:	<u>BMS-10P</u> <u>BMS-10PV</u>
Machine no.	:	_____
Applicable EU directives	:	RoHS directive (2011/65/EU) Low-voltage directive (2014/35/EU) EMC directive (2014/30/EU)
Applied harmonised standards, in particular	:	EN 60 974-1:2018 + A1:2019 EN 60 974-10:2016
Applied national standards	:	DGUV Regulation 1
Date	:	01 February 2021
Producer's signature	:	 _____
Signer's function	:	Managing Director



Table of contents

1	Safety instructions	8
1.1	<i>Description of reference signs in the operating instructions</i>	10
1.2	<i>Staff qualification and training</i>	11
1.3	<i>Dangers in the case of non-compliance with safety instructions</i>	11
1.4	<i>Before starting to weld</i>	11
1.5	<i>Working with the stud welding equipment</i>	11
1.6	<i>Inadmissible operating methods</i>	11
1.7	<i>Stopping the stud welding equipment</i>	11
2	General	12
2.1	<i>The following should be principally observed</i>	12
2.2	<i>Intended use</i>	12
2.3	<i>Marketing and service</i>	12
2.4	<i>Information on the documentation</i>	12
2.4.1	<i>Information on the operating instructions</i>	12
2.4.2	<i>Conduct in the case of malfunctions</i>	13
3	Description of stud welder	14
3.1	<i>Description</i>	14
3.2	<i>Capacitor discharge stud welding technology</i>	14
3.3	<i>Technical data</i>	15
3.4	<i>Interfaces BMS-10P</i>	16
4	Installation of the stud welding system	18
5	Start-up	19
5.1	<i>View</i>	19
5.1.1	<i>Main switch</i>	20
5.1.2	<i>Description of function keys</i>	20
5.1.3	<i>Description of LED displays</i>	20
5.1.4	<i>Description of display</i>	21
5.1.5	<i>Fuse element</i>	22
5.1.6	<i>Connecting elements</i>	22
5.1.7	<i>Description of symbols</i>	23
5.2	<i>Adjustment of operating modes</i>	24
5.2.1	<i>Starting the stud welder</i>	24
5.2.2	<i>Operating modes / parameters</i>	24
5.3	<i>Creating a new welding program</i>	25
5.4	<i>Copying a welding program</i>	26
5.5	<i>Deleting welding programs</i>	26
5.6	<i>Preparation for start-up</i>	27
5.6.1	<i>Earth connection</i>	27
5.6.2	<i>Connection of stud welding gun</i>	27
5.6.3	<i>Power supply</i>	27
5.7	<i>Welding parameters</i>	28
6	Operation	29
6.1	<i>Notes on the "Lifting test" operation mode</i>	30

6.2	<i>Adjustment of stud welding guns</i>	31
6.2.1	Basic setting of the stud chuck with set screw	31
6.3	<i>Start-up of PS-3 stud welding gun</i>	32
6.4	<i>Start-up of PS-3A welding gun</i>	34
6.5	<i>Quality control</i>	38
6.5.1	Setting up the quality control	38
6.5.2	Subsequent collection or completion of reference values	40
6.6	<i>Special functions</i>	41
6.6.1	Special function "Deleting RAM"	41
6.6.2	Special functions - "Extended submenu"	42
6.6.3	Special function "Setting the language. Display of software version number"	43
6.6.4	Special function "Setting the feeder times"	43
6.6.5	Special function "Setting the feeder operation"	44
6.6.6	Special function "Print protocol"	44
7	Quality control (stud welding)	47
7.1	<i>General instructions</i>	47
8	Maintenance	48
8.1	<i>Important instructions</i>	48
8.2	<i>Important instructions for all service works</i>	48
8.3	<i>Cleaning</i>	49
8.3.1	Detergents for cleaning the housing	49
8.4	<i>Replacement of components</i>	49
9	Troubleshooting	50
9.1	<i>Malfunctions</i>	50
10	Transport and storage	52
11	Terms of warranty	52
12	List of standards and guideline	53

1 Safety instructions

These safety precautions are for your safety.



General safety instructions

Take part in a training programme. Read and follow all safety precautions listed below and all chapters of this manual before starting to weld.

Non-compliance with the safety precautions can result in personal injuries or death.



Only qualified persons are allowed to operate and maintain the equipment.

Children and juveniles under the age of 16 years must be kept away from the equipment.



WARNING

It is prohibited to open the stud welding equipment.

The service personnel are required to meet special qualifications.

Our after-sales service has adequately trained personnel, suitable service equipment and the means to carry out all necessary works.



Warning of electromagnetic fields

Keep sufficient distance from electronic devices. When stud welding, highly intensive electromagnetic fields are created which may permanently damage these devices (e.g. television sets, airbags).



Ensure that the welding equipment is not operated near electronically sensitive life-support equipment, such as in intensive care units in hospitals.

Persons with pacemakers may neither operate the stud welding equipment nor stay in the immediate vicinity while it is running.



Electric shock can cause death

Prevent electric shock by insulating your body from the working area and the ground. Stand on dry insulating material and wear rubber soled shoes.

Inspect all cables including power cord for damage, wear or bare wiring.



Always ensure the correct supply voltage in accordance with the type plate. Never connect the welding equipment to a power supply network with incorrect supply voltage.

Always disconnect the welding equipment from the mains supply before starting any cleaning works. Only trained and appropriately qualified personnel are allowed to carry out works at the electric mains supply and welding system.

Do not touch live electrical parts with bare hand. Wear dry, hole-free insulating gloves.

Do not wear rings, watches or electrically conductive jewellery.

Keep the work area, studs, guns, cables, energy source as well as your clothes dry.

**Fumes and gases can cause damage to your health**

Fumes and suspended/floating particles may be generated during welding. Beware of fumes detrimental to health, particularly when using surface treated materials. Please also observe the safety regulations applicable for your country.

Do not inhale fumes and gases. Use adequate ventilation in the work area to remove fumes and gases.

**Welding can cause fire and explosions**

Welding sparks and heat from flames and arcs can cause fires. Keep a portable fire extinguisher within reach for immediate use. Be sure you are trained to use it.

When welding, do not wear clothes soiled with easily combustible substances such as oil, grease and paraffin oil etc.



Comply with the fire regulations and do not weld, for instance, in hazardous locations.



Pay attention to flammable objects at the welding place. All flammable materials and liquids, such as oil, fuel, etc. must be removed prior to the start of work.

Electronic equipment (e.g. airbags) and the use of explosive substances for fuel supply require further safety precautions when carrying out welding operations on cars. Appropriate information can be obtained from the trade associations or the car manufacturers.

**Skin and eye protection**

Arc rays and welding spatters can injure eyes and skin.

Wear safety glasses with side shields and protective goggles with correct shade of filter to protect your eyes from welding spatters and flashes of light that are generated during the welding process.



Wear gauntlet gloves made of leather as well as non-combustible closed working clothes such as heavy long-sleeve shirts, cuffless pants and safety shoes.



Wear a leather apron to protect your clothes from welding spatters.

Keep sleeves and collars buttoned and remove open pockets from the front side of your clothing.



We recommend using ear protection. Some welding and working processes may generate loud noises.

1.1 Description of reference signs in the operating instructions

The non-observance of safety instructions such as pictographs and warning words can cause damage to persons. The safety instructions of this operating manual describe the following.

Safety instructions



Danger! Immediate hazards which could result in serious personal injuries or loss of life.

Warning! Potential hazards which could result in serious personal injuries or loss of life.



Caution! Potential hazards which could result in minor personal injuries.

Caution! Warning of damage.











Note! Potential detrimental situation which may cause damage to the product or to an object surrounding it.



Important! Instructions for application and other useful information facilitating the proper use of the product.

Safety symbols

The following pictographs for warnings, prohibitions and regulations are used in this manual:

 <p>Prohibited for persons with pacemakers</p>	 <p>Prohibited (only in combination with an additional safety symbol)</p>	 <p>Do not touch Housing is current-carrying</p>	 <p>Fire extinguisher</p>
---	--	--	--

 <p>Warning of a danger spot</p>	 <p>Warning of dangerous electric voltage</p>	 <p>Warning of electromagnetic field</p>	 <p>Warning of moving parts</p>
---	--	--	--

 <p>General prohibition (only in combination with an additional safety symbol)</p>	 <p>Warning of inflammable substances</p>	 <p>Warning of explosive substances</p>	
---	--	---	--

 <p>Eye protection required</p>	 <p>Protective clothing required</p>	 <p>Ear protection required</p>	 <p>Protective gloves required</p>
--	---	---	---

 <p>General instructions are marked with the hand symbol.</p>
--

1.2 Staff qualification and training

The staff responsible for operation, maintenance, inspection and assembly must have the respective qualification for carrying out these works. Field of responsibility, competence and the supervision of staff must be carefully regulated by the user. If your personnel do not have the necessary knowledge, they must be trained and instructed. If necessary, this can be done by the manufacturer/supplier on behalf of the user. Furthermore, the user must ensure that the contents of the operating instructions have been fully understood by the staff.

The society of welding institutes (GSI: Gesellschaft der Schweißtechnischen Institute mbH) offers the appropriate training courses for your personnel.

For information on branches, please refer to website <http://www.dvs-ev.de>.

1.3 Dangers in the case of non-compliance with safety instructions

The non-compliance with safety instructions may not only endanger persons, but also the equipment and its environment. Any non-compliance with safety instructions may result in a complete loss of damage claims.

The following dangers may result if the safety instructions are not complied with:

- Failure of important system functions
- Failure of prescribed methods for maintenance
- Danger to persons through electrical, mechanical, thermal and/or acoustic influences.

1.4 Before starting to weld...

- Check the state of all cables and cable connections before starting to weld
- Immediately replace defective cables and cable connections.

1.5 Working with the stud welding equipment

Comply with all accident prevention regulations applicable to the operation of your welding device.

If an accident happens,

- switch off the welding device and disconnect it from the mains supply and
- call a doctor

1.6 Inadmissible operating methods

Limit values

The working safety of the stud welding equipment is only guaranteed when the system is used in accordance with its purpose. The limit values indicated in the chapter "Technical data" must never be exceeded.

1.7 Stopping the stud welding equipment

- Turn off the mains switch of the stud welding equipment.
- Disconnect the mains plug from the mains socket.
- In case of automatic operation, disconnect the compressed-air supply.
- Disconnect the earth cable from the stud welder.
- Disconnect welding gun or head from the stud welder.
- Roll up the cables without buckling them.
- Prevent the stud welder being operated by unauthorized personnel.
- Check welding cables and connections of the stud welder for damage such as burn-off, mechanical wear etc. and have damaged parts replaced by the SOYER customer service.



2 General

2.1 *The following should be principally observed...*

With the BMS-10P stud welder you have purchased a product which

- is state-of-the-art technology
- fully complies with the current safety requirements and
- ensures high performance.

Before installing the stud welder, please observe the following:

- Store the operating instructions in a place accessible to every operator.
- Ensure that the respective operator has read and understood the operating instructions prior to start-up. Each operator should confirm this per signature.
- Prevent the stud welder being operated by unauthorized personnel.
- Only trained personnel may operate the stud welder.

2.2 *Intended use*

The BMS-10P SOYER stud welder allows you to weld pins and threaded studs from M3 - M8 or Ø 3 - 7.1 mm and many other types of weld fasteners in accordance with DIN EN ISO 13918 (capacitor discharge) manufactured from steel, stainless steel, aluminium and brass.

If you need consultation or assistance in solving problems, please contact either our parent company or our field engineers.

2.3 *Marketing and service*

If you have any questions regarding the operation of the feeder, retrofits for special applications or if you require service, please contact your responsible service office or the following address:

Heinz Soyer Bolzenschweißtechnik GmbH

Inninger Straße 14

D-82237 Wörthsee

Telephone: +49 8153 8850

Telefax: +49 8153 8030

www.soyer.de

info@soyer.de

2.4 *Information on the documentation*

The following operating instructions are supplied with the BMS-10P stud welder:

- Operating instructions for BMS-10P **Order no.:** P02063

2.4.1 Information on the operating instructions

Legal relationship

We point out that the contents of these operating instructions are neither part of any former or existing arrangement, pledge or legal relationship nor have they been designed to modify the latter. All obligations of Heinz Soyer Bolzenschweißtechnik GmbH result from the respective contract of purchase. This contract also contains the complete and universally valid warranties. These contractual warranty terms are neither extended nor restricted by the implementation of these operating instructions.

**CAUTION**

Do not carry out any actions on the stud welding equipment without specifically knowing the operating instructions or the respective part. Ensure that only qualified and trained personnel familiar with the operating instructions operate the system.

2.4.2 Conduct in the case of malfunctions

If malfunctions occur, first try to detect and eliminate the causes according to the list in the "Troubleshooting" chapter of these operating instructions. In all other cases, contact our service department.

If you require our service, please make sure that you supply us with the following information:

- Customer number
- Product designation / options
- Serial number
- Year of construction
- Material of stud and workpiece
- Stud dimensions

This information helps us save time and unnecessary costs, e.g. incurred by delivering the wrong spare parts.

3 Description of stud welder

3.1 Description

The BMS-10P SOYER stud welder is universally applicable for both manual and automatic operation. Control via a serial CNC interface is possible.

The BMS-10P stud welder enables the storage of parameters for various welding tasks as welding programs. These parameters can be recalled at any time. To simplify operation, it is possible to store programs for different stud diameters. This allows a more rapid and simpler interchange of different welding tasks. The integrated quality control allows the most important parameters of the weld to be monitored and any welding faults to be reported when inadmissible deviations occur.

The stud welder is equipped with eight keys, eight light-emitting diodes (LED) and a two-lined text display at the front panel. The stud welder is adjusted via the keys. The operating state during welding is shown by the light-emitting diodes and on the display.

3.2 Capacitor discharge stud welding technology

The BMS-10P SOYER stud welder runs according to the principle of capacitor discharge with tip ignition as defined in DVS Leaflet 0903 (DVS = German Welding Society). This system uses the sudden discharge of a capacitor battery to generate arc energy.

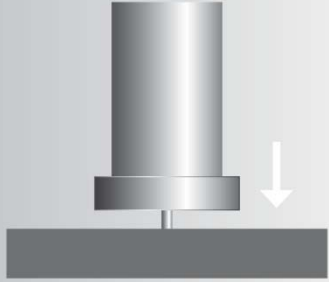
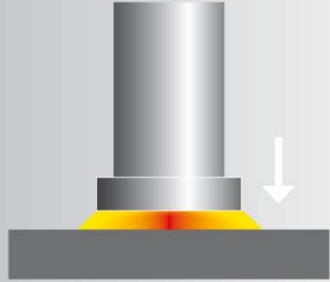
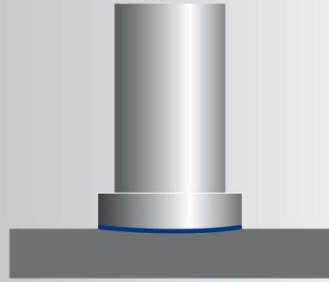
		
<p>Stud tip touches workpiece.</p>	<p>Ignited arc generates a fusion zone on stud and workpiece.</p>	<p>Stud is plunged into the welding pool. Material solidifies and stud is welded.</p>

For further information, please refer to www.soyer.de



IMPORTANT INFORMATION

Ensure that the surface is electroconductive.
Grind coated parts.

3.3 Technical data

Designation	BMS-10P
Welding process	Capacitor discharge stud welding
Standard gun	PS-3
Welding range	M3 - M8 or Ø 3 - 8 mm with steel, stainless steel, aluminium and brass (M8 or Ø 8 in aluminium and brass conditionally, depending on the respective requirements)
Power source	Capacitor bank with capacitance change-over 33,000 / 99,000 µF
Charging voltage	60 - 200 V infinitely variable up/down
Welding sequence	Up to 20 studs/min (depending on stud diameter and type of feed)
Power supply	230 V, 50/60 Hz, 10 A (*2 OPTION 115 V)
Fuse	T 10 A (5 x 20 mm time-lag fuse)
Type of cooling	F
System of protection	IP 21
Dimensions	430 x 220 x 560 mm (w x h x d)
Weight *1	26 kg *1
Colour	RAL 5009 azure blue
Technical specifications are subject to change without notice	

	<p>WARNING</p> <p>The "S" symbol is the symbol for welding current sources permitted for operation with increased electrical danger. The "S" symbol on our stud welders refers exclusively to the welding current circuit and not to the complete stud welding equipment.</p>
---	--

*1 Slight deviations are possible depending on accessories.

*2 The BMS-10P stud welder is suitable for operation with 115 V or 230 V. Please refer to the type plate for the current mains supply.

3.4 Interfaces BMS-10P

CNC interface

The CNC interface serves for the control and communication e.g. in conjunction with a CNC stud welding machine.

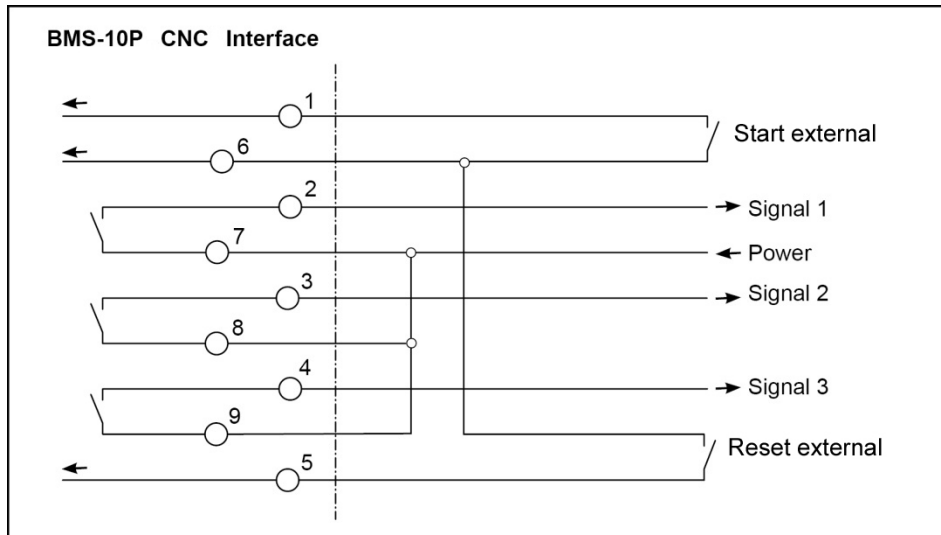

PIN		Description of 9-pole D-Sub female connector (CNC interface)
1 + 6	Start external	Contact releases the welding process.
2 + 7	Signal 1	Weld is OK: Contact is present during operation. It is interrupted in case of a faulty weld.
	Power	Contact load: max. 24 V, 200 mA
3 + 8	Signal 2	Stud onto workpiece Contact is made when stud touches the workpiece.
4 + 9	Signal 3	Charge is ready Contact is made after the set charging voltage has been reached.
6 + 5	Reset external	Error reset, external Contact resets error messages.

RS 232-interface (bidirectional communication interface)

The RS 232 interface serves as a "printer interface" or as "remote control" e.g. in conjunction with a CNC stud welding machine. A complete device configuration for the central control via a PC is possible via the interface. Operation via the eight function keys is therefore no longer necessary.

Technical data of interface: 9-pin plug - Connector pin assignment			
PIN	Signal	Adjustment: 9600 baud	
2	RxD	8	Data bits
3	TxD	1	Stop bit
5	Ground	no	Parity

p-Select – interface

Communication interface for the P3-Select/S gun distribution system. This interface serves for the automatic selection of programs (for further information, please refer to the operating instructions of the P3-Select gun distribution system).

Feeder – interface

The feeder interface serves as the control and communication of our systems for the automatic stud reload of e.g. UVR-300 SOYER universal feeders.

Isolated ground receptacle 3.15 A

The isolated ground receptacle exclusively serves as power supply for our universal feeders or additional accessories such as welding heads.

	<p>NOTE The operating voltage of the isolated ground receptacle corresponds to the current mains voltage.</p>
---	--

	<p>CAUTION The isolated ground receptacle is protected by 3.15 A. <u>Never</u> connect any additional "appliances" such as stud welders.</p>
--	---

Setting the mains voltage for 115 V or 230 V

The BMS-10P stud welder is suitable for two power supply voltages: 115 V or 230 V. The factory-set mains connection values are indicated on the type plate of the welding equipment.

The mains voltage can be changed by reconnecting the corresponding connection terminals at the mains transformer.

For further information, please contact your responsible SOYER service office.

	<p>CAUTION If the operating voltage is changed by reconnecting the connection terminals at the mains transformer, the specifications on the type plate have to be changed accordingly.</p>
---	---

	<p>CAUTION Only authorized specialist electricians are allowed to carry out works at the electric mains supply!</p>
---	--

4 Installation of the stud welding system

- Only install the stud welder on an even surface. The pads located on the bottom of the welding equipment guarantee its anti-skid position and serve as vibration dampers.
- Although the stud welder is resistant to environmental influences, it should be protected against dampness and dust.
- Please pay particular attention to the bearing strength of the workshop furniture and ensure a safe and stable position for the welding equipment.
- Make sure there is sufficient free space around the air apertures, otherwise the device safety mechanism will respond and interrupt the welding process.
- Install the stud welder close to the welding location.
- Ensure sufficient ventilation of the working room when operating the welding system.

**NOTE**

The casing of the stud welder corresponds to safety class IP 21. Please note that this system of protection is not suitable for operation or transportation in the rain.

- **Ensure correct connected loads for electrical connections as indicated on the type plate.**

5 Start-up

5.1 View

Front view

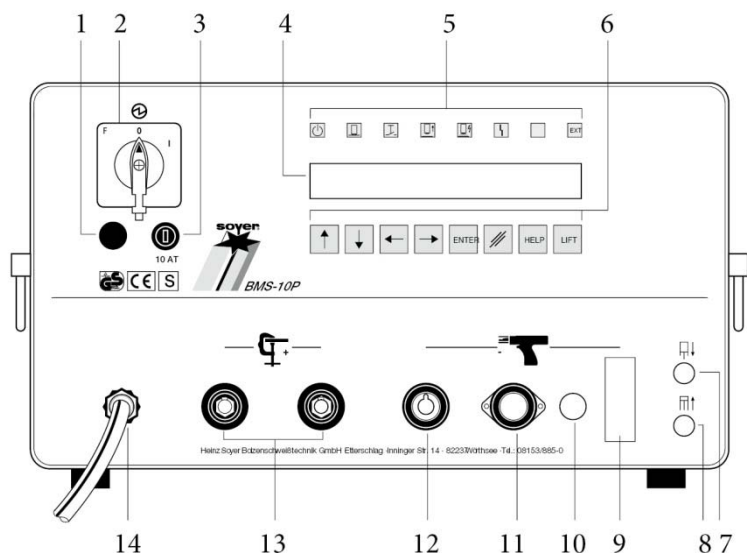

1. No function
2. Main switch
3. Fuse element F 1 with fuse 10 AT
4. LCD display
5. LED displays
6. Function keys
7. Air function "forward"
8. Air function "back"
9. Control cable socket
10. Test jack GUN
11. Test jack EARTH
12. Gun cable socket
13. Earth cable connectors
14. Mains cable

Rear view

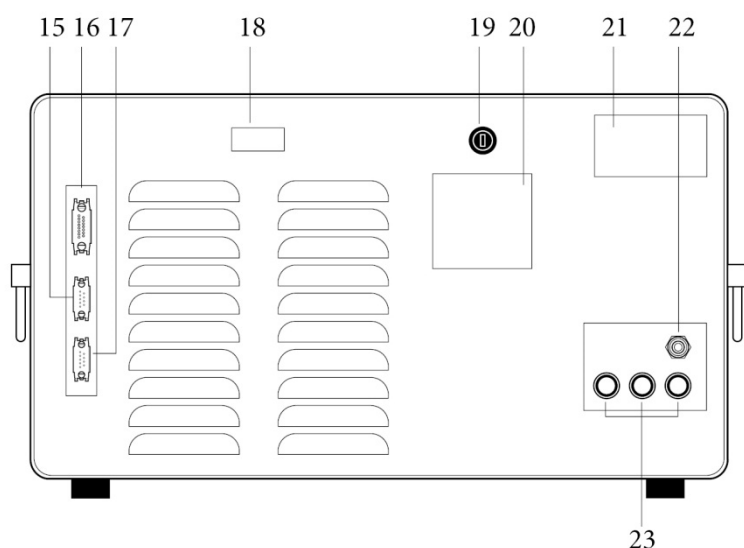

15. CNC interface
16. Feeder interface
17. Interface RS 232
18. Interface p-Select
19. Fuse element with fuse 3.15 AT
20. Schuko plug socket 230 V ~ 3.15 A
21. Type plate
22. Compressed-air supply
23. Connection sockets for the compressed-air control of the feeder

5.1.1 Main switch

Main switch

The main switch is used to switch the stud welder on and off.

5.1.2 Description of function keys

The BMS-10P stud welder has eight function keys at the front panel which allow different types of functions to be carried out.

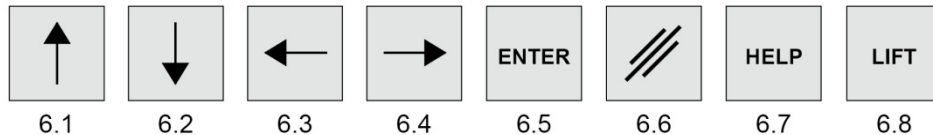

Key	Description
6.1 "Arrow up"	Modification of selected parameters (flashing symbol in display)
6.2 " Arrow down"	Modification of selected parameters (flashing symbol in display)
6.3 " Arrow left"	Selection of parameters to be modified (shifting of the flashing symbol to the left)
6.4 " Arrow right"	Selection of parameters to be modified (shifting of the flashing symbol to the right)
6.5 "ENTER"	Creating a new program or copying an existing program
6.6 "DELETE/CLEAR"	Deletion of a program
6.7 "HELP"	Explanation of the parameters shown in the display
6.8 "LIFT"	Activating the lifting magnet of the welding gun

5.1.3 Description of LED displays

The respective operating states may be read via the LED displays.



LED	Description
5.1 LED "Ready"	LED lights up when capacitor battery has been charged to the set value.
5.2 LED "SOW"	LED lights up as soon as the stud touches the workpiece provided the workpiece is connected to the earth pole of the stud welder.
5.3 LED "Release"	LED lights up when pressing the trigger switch of the gun or when the start signal at the external interface has been activated.
5.4 LED "Lift"	LED lights up as soon as the lifting magnet of the gun has been activated.
5.5 LED "Ignition"	LED lights up when stud is ignited (welding process).
5.6 LED "Error"	LED blinks when the welding parameters are outside the tolerance limit with the quality control being switched on.
5.7 LED "Quako"	LED lights up when the stud welder is equipped with a quality control and when the quality control works faultlessly.
5.8 LED "External"	LED only lights up during internal quality test run (service mode).

5.1.4 Description of display

A parameter designation is shown blinking in the display to indicate that its value can be altered using the keyboard.

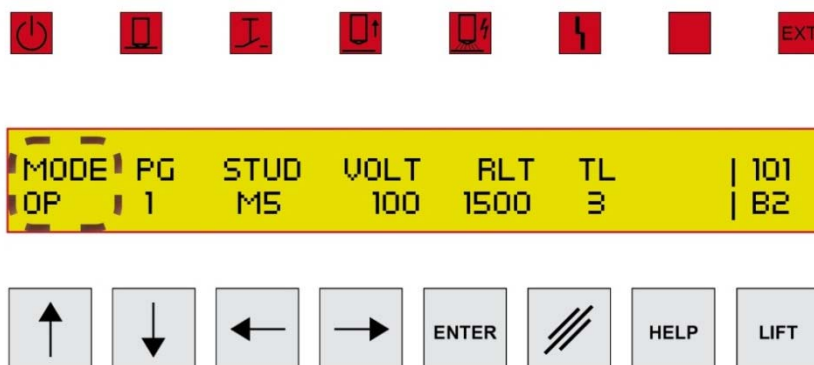

Example of a display shown after stud welder has been switched on:

- The measured charging voltage of the capacitor bank is displayed **at the top right**.
Example: |101 Current charging voltage is 101 V
- The current capacity of the capacitor bank is displayed **at the bottom right**.
Example BMS-10P: B1 = 33,000 μ F | B2 = 99,000 μ F

Description of operating parameters (MODE)



Parameter	Description
OP	Operation. Standard setting for normal welding operation. The parameters of the programs can only be altered in this mode.
LIFT	Lift test. It allows activating the lifting magnet of the gun/head to control the setting without welding operation .
MEAS	The operating mode "MEAS" allows you to determine the desired values for a welding program (pls. refer to the description of the quality control).

Setting options for welding operation (OP)

Parameter	Description	Range
PG	Number of the set program.	1 - 6
STUD	Stud type. Only serves as information and has no effect on the weld.	M3 – M8
VOLT	Adjusted charging voltage of the capacitor battery in volt. Please note: In addition, the measured charging voltage of the capacitor battery will also be shown on the display.	60 – 200 V
RLT	Reload time in milliseconds (only with automatic operation)	0 - 9900 ms
TL	Tolerance. Admissible deviation of quality control. 0 = Quality control is switched off. 1 = minimum tolerance limit, 10 = maximum tolerance limit	0 - 10

5.1.5 Fuse element

The BMS-10P stud welder is protected by a 10 AT fuse.

 	<p>CAUTION</p> <p>Should it become necessary to replace fuses, only use those with specified electrical values. Oversized fuses could either cause defects to the electrical system or a fire.</p> <p>Always disconnect the mains plug from the power supply when replacing fuses!</p>
---	---

5.1.6 Connecting elements

Mains cable

The mains cable serves to connect the stud welder to the power supply.

	<p>Ensure correct connected loads for electrical connections as indicated on the type plate of the stud welder.</p>
--	--

Earth cable socket

The earth cable socket serves to connect the earth clamps to the stud welder.

Control cable socket and welding cable socket

The control cable socket and welding cable socket serve to connect the stud welding gun to the stud welder.

- **Test jack GUN**

The test jack GUN serves to connect the measuring line of the gun.

- **Test jack GROUND**

The test jack GROUND serves to connect the measuring line of the ground connection.



















- **Air function "forward"**

Connection for welding guns or heads with automatic stud feed.

- **Air function "back"**

Connection for welding guns or heads with automatic stud feed.

5.1.7 Description of symbols

Symbol	Designation	Function
	LED "Ready"	LED lights up when stud welder is ready for operation.
	LED "Stud on Workpiece"	LED lights up when earth terminal of stud welder is connected and stud touches the workpiece.
	LED "Release"	LED lights up when pressing release button of welding gun or welding head.
	LED "Lift"	LED lights up with lifting magnet of welding gun being activated.
	LED "Ignition"	LED lights up when stud is ignited (welding process).
	LED "Error"	LED lights up when weld is outside the tolerance.
	LED "External"	LED lights up when the stud welder is operated by remote control via the serial interface, (RS 232).
	Function key "ALTER PARAMETERS"	Upward alteration of selected parameters (represented blinking in the display).
	Function key "ALTER PARAMETERS"	Downward alteration of selected parameters (represented blinking in the display).
	Function key "SELECT PARAMETERS"	Selection of parameters to be changed (shifting of the blinking symbol to the left).
	Function key "SELECT PARAMETERS"	Selection of parameters to be changed (shifting of the blinking symbol to the right).
	Function key "ENTER"	Creating and copying programs.
	Function key "CLEAR/DELETE"	Deletion of a user program.
	Function key "HELP"	Help function. Explanation of parameters in the display.
	Function key "LIFT"	Activating the lifting magnet of the welding gun/welding head or the gas valve.
	Air function "forward"	Air supply of stud welding gun/welding head with automatic operation.
	Air function "back"	Air supply of stud welding gun/welding head with automatic operation.
	Gun	Marks control and welding cable sockets to be connected with welding gun/welding head.
	Earth	Marks earth cable connector to be connected with earth cable.

5.2 Adjustment of operating modes

5.2.1 Starting the stud welder

After switching on the stud welder, the 8 LED lamps light briefly. The stud welder carries out a self test.

After the self test has been carried out successfully, the stud welder automatically sets the parameters which were last set.

5.2.2 Operating modes / parameters

Press the function key "Arrow right" or "Arrow left" to select the parameters. Only the parameter designation which is flashing on the display can be set by means of the function keys.

- Operating mode "OP" (Operation)

MODE	PG	STUD	VOLT	RLT	TL	101
OP	1	M5	100	1500	3	B2

This operating state must be set for normal welding operation. When the quality control is switched on, the stud welder locks if welds are outside the tolerance. It can be reset by pressing the LIFT key or ENTER key (please refer to the description of the quality control).

- Operating mode "LIFT" (Lift Test)

This operation mode enables you to adjust and check the lift of the gun or welding head. For further information, please also refer to the operating instructions for the welding gun or welding head.

- Use the function key "Arrow up" or "Arrow down" to set operation mode "LIFT".



MODE	Test lift	:	Trigger key	0
LIFT	Drop time	:	mS	V



- Insert a stud into the welding gun or welding head.
- Check the immersion depth of the stud and set it according to the operating instructions of the welding gun or welding head.



CAUTION

Ensure once again that the operation mode is set to "LIFT" and comply with the safety instructions in chapter 1.

- Position gun or welding head on workpiece. The LED "Stud on workpiece" lights up.
- Press the release button of the gun or the welding head or give a triggering signal via the CNC interface. The weld stud is lifted off the workpiece as long as the triggering signal is there.

If necessary, check and correct the height of lift according to the specified standard values.

If the lift test is carried out on a workpiece which is connected to the earth connection of the stud welder, the drop time will be shown in milliseconds on the display. If the workpiece is not connected to the earth connection, "No grounding" appears on the display.

```

MODE  Test lift  :  Trigger key  | 0
LIFT  Drop time  :  No grounding  | U
  
```

	<p>NOTE</p> <p>Do not activate the release too often at short intervals. This can cause the thermo safety mechanism protecting the lifting magnet to react and the current supply for the magnet will be interrupted. This condition is shown as error message on the display.</p>
---	---

- **Operating mode "MEAS" (Measuring)**

The operating mode "MEAS" allows you to determine the desired values for a welding program (see description of quality control).

5.3 Creating a new welding program

	<p>NOTE</p> <p>No welding parameters are stored when starting up the stud welder for the first time or after resetting the stud welding equipment. Welding operation is only possible when welding parameters have been stored!</p>
---	---

- Set "MODE" parameter to "OP".
- Choose a program that is still available.

```

MODE PG  STUD  VOLT  RLT  TL  | 0
OP  1  Program available  | B
  
```

Press the "ENTER" key. A new program with standard values (M5) is created under the set program number. The standard values of this new program can now be altered by means of the function keys.

```

MODE PG  STUD  VOLT  RLT  TL  | 101
OP  1  M5    100  1500  3  | B2
  
```



5.4 Copying a welding program

Welding programs should be copied when carrying out further parameter tests to save values already determined.

- Set "MODE" parameter to "OP".
- Choose a program that is already occupied.
- Press the "ENTER" key.

The following message appears on the display:

```
Program 1 to be stored in programm 2
Select: arrow up/down, Store: arrow left
```

The stud welder displays the first free program site available where you can store the program to be copied. However, you can also select another free program site by means of the "Arrow up/down" keys. Press "Arrow left" key to store the program to be copied. The copied program appears on the display. Reference values which have been stored for the quality control will also be copied.

5.5 Deleting welding programs

It is possible to delete user welding programs which are no longer required in order to have a clearly arranged program overview.

- Set "MODE" parameter to "OP".
- Select the program to be deleted on the display.
- Press /// - key (delete key).

The following message appears on the display:

```
Is program 3 to be cleared ?
Yes: arrow left No: arrow right
```

The function can be terminated by pressing the "Arrow right" key without deleting the selected program. This proves to be useful if the /// key has been pressed unintentionally.

The selected program is deleted by pressing the "Arrow left" key and shown as free program on the display.

5.6 Preparation for start-up

	<p>The start-up procedure described in this section applies to the stud welder in combination with a SOYER stud welding gun. When starting up the stud welder in conjunction with a SOYER stud welding machine (NC, CNC), the work steps must be followed accordingly. With a complete stud welding system, however, the cable connections are usually already factory-provided.</p>
---	--

Connect the stud welding gun and earth cables to the stud welder prior to start-up.

5.6.1 Earth connection

- Attach earth cable to earth cable connectors and lock by turning to the right until stop.
- Attach earth clamps to workpiece.

	<p>Ensure optimum contact with workpiece. → If necessary, grind the area to be welded (contact area must be metallicly bright).</p>
---	---

5.6.2 Connection of stud welding gun

- Connect welding cable of welding gun to the welding cable socket and lock it by turning to the right until stop.
- Insert control cable into control cable connection and tighten it.
- Connect measuring cable to test jack (OPTION).

5.6.3 Power supply

- Connect mains cable to power supply.

	<p>MORTAL DANGER Ensure correct connected loads for electrical connections as indicated on the type plate. Only connect stud welder to approved isolated ground receptacles.</p>
---	--

5.7 Welding parameters

	<p>NOTE</p> <p>The set welding parameters influence the reproducibility and quality of the welding results to a large extent. The parameters depend on the size of the studs and the material properties. The values indicated in the tables are standard values which are exclusively valid for studs supplied by SOYER. They may vary depending on the type of workpiece, the workpiece thickness, the surface condition of the workpiece and on environmental conditions (e.g. low outdoor temperatures). The settings of the welding gun or welding head also influence the welding parameters (e.g. if the lift is increased, usually the charging voltage must be increased too).</p>
---	--

Random samples should be taken during any production process to ensure consistently good welding results (see DVS guideline, Part 1, "Quality assurance of stud welding joints").

The welding parameters were determined with the BMS-10P stud welder and the PS-3 stud welding gun using a lift adjustment of about 2.5 mm. A steel plate with a thickness of 2 mm served as base metal for welding copper-plated CD studs (4.8) as per DIN EN ISO 13918.

Charging voltage table (in volt) BMS-10P

The charging voltage is preset according to the table. It can be adapted via the function keys depending on the respective welding task.

	<p>NOTE</p> <p>Depending on the charging capacity of the battery (Battery 1 = 33,000 μF Battery 2 = 99,000 μF), different values for the charging voltage are specified.</p>
---	---

Values for charging capacity 99,000 μ F (Battery 2)

Parameter	Charging voltage (V)	Setting range (V)
M3 [Ø3]	60	50 - 75
M4 [Ø4]	80	60 - 100
M5 [Ø5]	100	75 - 125
M6 [Ø6]	120	95 - 145
M7.1 [Ø7.1]	140	95 - 145
M8 [Ø8]	160	125 - 200

Values for charging capacity 33,000 μ F (Battery 1)

Parameter	Charging voltage (V)	Setting range (V)
M3 [Ø3]	60	60 - 200
M4 [Ø4]	95	80 - 200
M5 [Ø5]	110	90 - 200
M6 [Ø6]	130	100 - 200
M7.1 [Ø7.1]	160	110 - 200
M8 [Ø8]	190	120 - 200

6 Operation

	<p>NOTE The relevant accident prevention and safety regulations must be complied with when operating the stud welder.</p>
---	--

	<p>NOTE The welding areas must be metallically bright. → If necessary, grind the area to be welded.</p>
---	--

- Switch on mains switch.

	<p>After switching the stud welder on, all eight LED lamps light up for a short period. Depending on the respective operating state, further messages are shown via the digital display.</p>
---	--

- Set desired operating mode "OP" or "MEAS".
- Choose charging voltage depending on stud diameter by means of the function keys.

	<p>NOTE Please observe the following when using welding guns equipped with a lifting magnet (e.g. PS-3, SK-5AP): → Check the setting for the height of lift.</p>
--	---

- Position welding gun with weld stud on the workpiece. When earth connection is made and the stud in the gun touches the workpiece, the LED "Stud on Workpiece" lights up.
- Press the push button. The LED "Release" lights up and stud welding process is started.

During the welding process, keep the gun steady. After completion of the welding process, remove gun vertically from the welded stud. A possible operating error e.g. the welding gun glides off during welding, is identified by the stud welder and indicated as failure by LED "Malfunction" lighting up. After removing the welding gun from the welded stud, the capacitor bank is recharged. The stud welder is ready for welding again after a few seconds (LED "Ready" lights up). In case of automatic operation, a weld stud will be reloaded.

6.1 Notes on the "Lifting test" operation mode

The lifting test allows for the activation of the gun's lifting magnet thus being able to control the setting.

Proceed as follows:

- Provide ground connection to the workpiece, connect welding gun.
- Mount stud chuck to the welding gun and insert weld stud into stud chuck.
- Select operation mode "Lift test".

```

MODE      Test lift   :   Trigger key   | 0
LIFT      Drop time  :   No grounding  | V
  
```

- Actuate the release button. A lifting cycle is carried out using the control parameters of a real weld.

	<p>NOTE The appropriate lifting height can be adjusted by rotating the adjusting cap at the rear side of the welding gun to the left or to the right. The lifting height shall amount to approximately 2 mm.</p>
---	--

This procedure can be repeated as frequently as required. To avoid overheating the magnetic coil, a waiting time of approx. one second must be observed between two test lifts.

If at the beginning of the lifting cycle **BAW** (**SOW** = stud positioned on workpiece) is recognised, the stud welder will display the drop time of the gun in ms (milliseconds) with a resolution of 0.1 ms. This time measurement starts with the activation of the lifting magnet and stops as soon as the stud touches the workpiece.

```

MODE      Test lift   :   Trigger key   | 0
LIFT      Drop time  :   9.8 mS         | V
  
```



If the lifting cycle is accomplished without prior **BAW/SOW** (no ground connection), the symbol [- - -] is displayed.

Set stud welder to "OP" operation mode (welding operation) to complete the test.

BAW /SOW signal "Stud positioned on Workpiece"



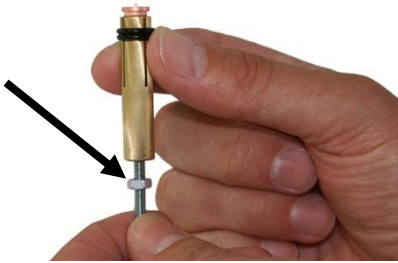
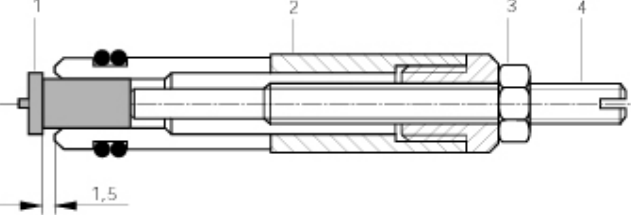
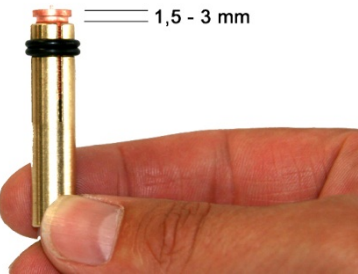

6.2 Adjustment of stud welding guns

6.2.1 Basic setting of the stud chuck with set screw

	<ul style="list-style-type: none"> • The stud chucks with set screw of the PS-1, PS-3, PS-3K, PS-0K and PS-1K stud welding guns are all of the same style. • For different stud diameters, different stud chucks are required. • For the PS-1, PS-3, PS-3K, PS-0K and PS-1K welding guns, use the standard stud chuck of 40 mm length with set screw. Ensure that the maximum stud length does not exceed 35 mm. • When using long weld studs with the small-sized PS-0K and PS-1K welding guns, however, it is necessary to shorten the stud chucks' stop screw.
	<p>Insert weld stud into stud chuck.</p>
	<p>The weld stud must make contact with the stop screw. Adjust stop screw in the stud chuck by turning it until the distance between the top edge of the stud flange and the front edge of the stud chuck equals 1.5 mm.</p> <p>Secure stop screw (4) by means of counter nut (3).</p>  <p style="text-align: right; font-size: small;">S206-0598 (012)</p>
	<p>Ensure depth of immersion / stud protrusion is set between 1.5 mm and 3 mm.</p> <p>After adjustment, check and correct if necessary. Hand-tighten by means of the fixing nut.</p>

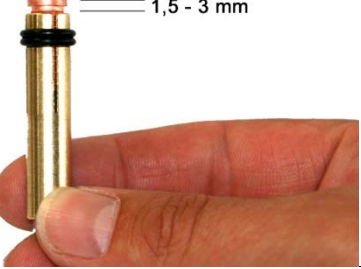
6.3 Start-up of PS-3 stud welding gun

Note: The PS-3 stud welding gun is only suitable for stud sizes M3 - M8!

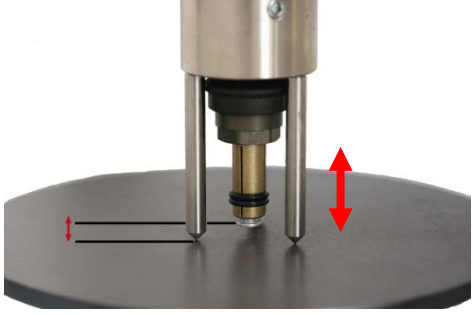
	<p>Ensure depth of immersion / stud protrusion is set between 1.5 mm and 3 mm. After adjustment, check and correct if necessary. Hand-tighten by means of the fixing nut.</p>
	<p>The stud welder must be <u>switched off</u> when installing the stud chuck.</p> <p>Loosen sleeve nut by means of SW 17 socket wrench.</p> <p>Insert the chuck into the spring piston and push it firmly until it comes to a stop.</p> 
	<p>Hand-tighten sleeve nut by means of SW 17 socket wrench.</p>
	<p>Ensure stud protrusion is set between 1.5 mm and 3 mm</p> <p>The stud/stud flange must protrude for about 1.5 – 3 mm from the tips of the gun legs or support tube. If necessary, dismount stud chuck again and correct the stud protrusion.</p>
	<p><u>Adjusting and checking the height of lift</u></p> <p>The height of lift is the distance for which the weld stud is lifted from the workpiece during the welding process.</p> <p>The height of lift should amount to approx. 2 mm.</p>

- Switch the BMS-10P stud welder on using the main switch.
- Choose operation mode "LIFT" on the stud welder.

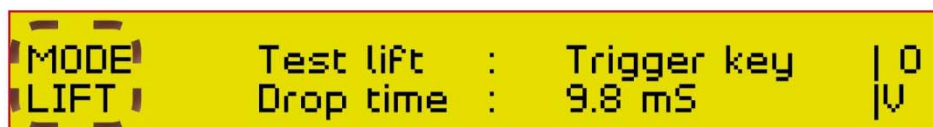

- Position welding gun on the workpiece
- Press push button. The gun lifts the chuck with weld stud away from the workpiece

Adjustment of the gun lift is achieved by turning the rear adjustment cap of the welding gun to the left or to the right.

Anti-clockwise rotation increases the gun lift and conversely clockwise rotation reduces the gun lift.

The height of lift should amount to approx. 2 mm.

NOTE:

If the lift test is carried out on a workpiece which is connected to the earth connection of the stud welder, the drop time will be shown in milliseconds on the display. If the workpiece is not connected to the earth connection, "No grounding" will appear on the display.

Choose operation mode "OP" on the stud welder.



- Is the charging voltage set according to the stud diameter?
- Check and correct if necessary.



Position welding gun vertically on the workpiece (at a 90-degree angle to the workpiece). Check once again the selected parameters. Release welding process by pressing the push button.

During the welding process, keep the gun steady. After completion of the welding process, remove gun vertically from the welded stud to prevent widening and damaging of the stud chuck.

Please carefully observe all safety instructions!



6.4 Start-up of PS-3A welding gun

The PS-3A welding gun is suitable for PT welding studs as per DIN EN ISO 13918 from M3 – M8 and a maximum stud length of 35 mm.

The stud welding gun is usually supplied in a ready-to-use condition. Prior to start-up make sure, however, that the appropriate conversion kit for the weld stud to be used has been installed. Replace conversion kit if need be.

The conversion kit allows weld studs to be automatically fed via a stud feed tube into the stud chuck (3). The plunger (2) in conjunction with differing distance sleeves (4) serves as a limit stop for weld studs (1) of different lengths.

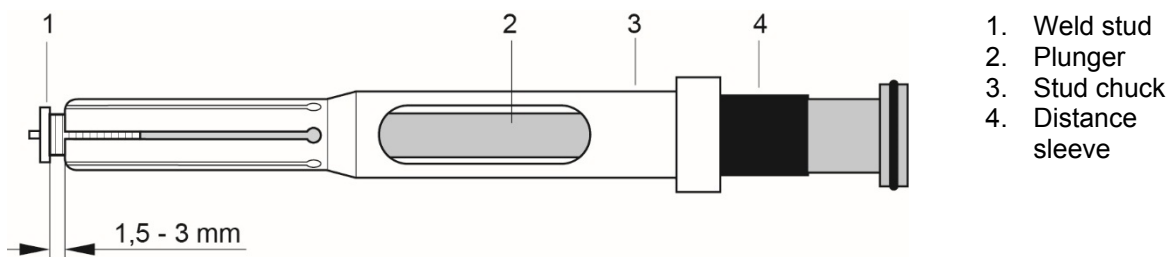

ATTENTION! DISCONNECT COMPRESSED AIR!

Disconnect the air connections located on the front panel of the stud welder prior to replacing the conversion kit. Please ensure that the stud welder is switched off.



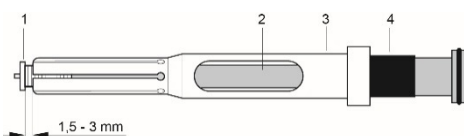

Connect welding cable and control cable of the stud welding gun.

Do not connect compressed air yet!

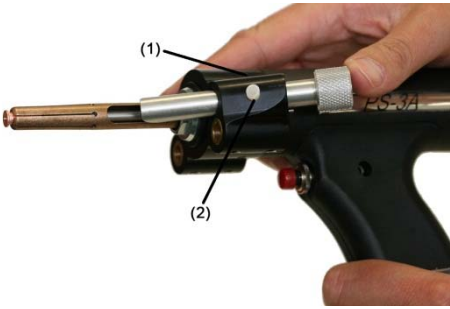

Adjustment of automatic stud chuck

- Choose conversion kit for the respective stud diameter.
- Insert weld stud into the opening of the stud chuck (ignition tip and/or stud flange must point in the direction of the chuck collets of the stud chuck).
- Insert plunger into stud chuck and press stud flange through the chuck collets until the distance between the top edge of the stud flange and the front edge of the stud chuck equals 1.5 mm – 3 mm.
- Insert a single distance sleeve or a combination of distance sleeves between the plunger and the stud chuck.

	<p>Please note:</p> <p>To facilitate the installation of the stud chuck, move or dismantle the support.</p> <p>For doing so, loosen the four Allen screws.</p>
	<ul style="list-style-type: none"> Loosen sleeve nut by means of SW 17 socket wrench. Insert the chuck into the spring piston and push it firmly until it comes to a stop (ensure correct mounting position). Fix stud chuck with sleeve nut and hand-tighten it by means of SW 17 socket wrench.
	<ul style="list-style-type: none"> Move stud feed tube through the support retainer until it comes to a stop. Ensure exact positioning while doing so. Tighten stud feed tube with grub screw (2). <p>Please note: Loosen grub screw (2) and press in the locking pin (1) when mounting or dismantling the welding gun.</p>
	<ul style="list-style-type: none"> Connect compressed air (min. 5 bar; max. 7 bar) to the main air connection of the stud welder. Connect compressed-air hose "V" of the welding gun to the air function "forward" and compressed air hose "Z" to the air function "back". <p>Please ensure that compressed air is dry and clean!</p>
	<p>How to correct the stud protrusion</p> <ul style="list-style-type: none"> Insert the stud into the chuck and push it firmly until it comes to a stop. Use Allen wrench SIZE 3 to loosen the four Allen screws. Move support until the respective stud protrusion of approx. 1.5 - 3 mm is obtained. Tighten Allen screws again.

Ensure stud protrusion is set between 1.5 mm – 3 mm!

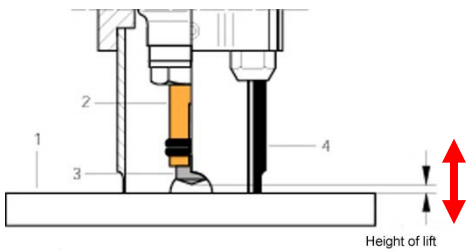
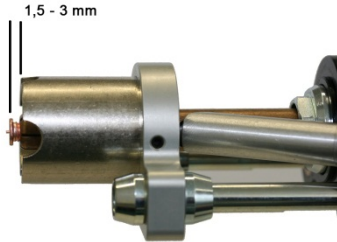

Adjusting and checking the height of lift

The height of lift is the distance for which the weld stud is lifted from the workpiece during the welding process.

The height of lift should amount to approx. 2 mm.

- Switch the BMS-10P stud welder on using the main switch.
- Choose operation mode "LIFT" on the stud welder.



NOTE:

If the lift test is carried out on a workpiece which is connected to the earth connection of the stud welder, the drop time will be shown in milliseconds on the display. If the workpiece is not connected to the earth connection, "No grounding" will appear on the display.



- Position welding gun on the workpiece
- Press push button. The gun lifts the chuck with weld stud away from the workpiece

Adjustment of the gun lift is achieved by turning the rear adjustment cap of the welding gun to the left or to the right.

Anti-clockwise rotation increases the gun lift and conversely clockwise rotation reduces the gun lift.

The height of lift should amount to approx. 2 mm.

Choose operation mode "OP" on the stud welder.

MODE	PG	STUD	VOLT	RLT	TL	101
OP	1	M5	100	1500	3	B2

- Is the charging voltage set according to the stud diameter?
- Check and correct if necessary.



Position welding gun vertically on the workpiece (at a 90-degree angle to the workpiece). Check once again the selected parameters. Release welding process by pressing the push button.

During the welding process, keep the gun steady. After completion of the welding process, remove gun vertically from the welded stud to prevent widening and damaging of the stud chuck.

Please observe carefully all safety instructions!



6.5 Quality control

The quality control serves to monitor the reproducibility of the welding process and to report inadmissible deviations. Thus changes can be detected which impair the quality of the welding results.

All welds are monitored when the quality control is switched on. The current weld in real-time is always compared with the stored reference values. If these values are outside the specified tolerance, the stud welder will be locked for welding operation. It can be reset by pressing the LIFT key or ENTER key.

Pristine condition and regular maintenance of the entire welding equipment (welding gun/head, CNC table, robot, earth connections etc.) are prerequisites for the successful application of the quality control.

The SK-5AP welding head or PS-3A / PS-3P welding guns are suitable for the quality control when equipped with a measuring lead (special design).

6.5.1 Setting up the quality control

Before using the quality control system, it is necessary to determine desired values for the welding program to be used. Please proceed as follows:

- Set operation mode "OP".
- Set parameters required for the welding task. Carry out test welds. If need be, readjust parameters.
- Set operating mode "MEAS" when the welds correspond to the quality desired.



NOTE

Parameters cannot be altered in operating mode "MEAS".

The following message appears on the display:

To add measured || To record new meas.
values Arrow left || values Arrow right

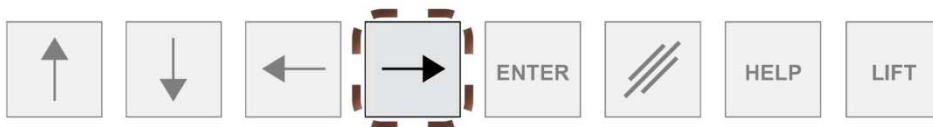

Call the option "Record new measured values" by pressing the "Arrow right" key.

```

MODE PG  STUD  VOLT  RLT  TL  | 101
MEAS 1    M5   100  1500 3  | B2
  
```

Carry out test welds. The following message appears on the display:

Store Arrow left / Reject Arrow right

If the weld is perfect and corresponds to the quality expected (bend test or tensile strength test), it can be used as reference weld. If satisfied with the result, confirm option "Store Arrow left" by pressing the "Arrow left" key immediately after welding or otherwise reject by means of "Arrow right" key.

It is necessary to carry out approximately 20 to 30 test welds!

Welding operation with the quality control

- Set operation mode "OP".
- When terminating operating mode "MEAS", the measured results of the test welds carried out are entered as reference values into the set program.
- Switch on the quality control.

```

MODE PG  STUD  VOLT  RLT TL  | 101
OP      1   M5   100  1500 3  | B2
  
```

Select the admissible deviation of the quality control

Value TOL = Tolerance O = Quality control off.
 1 = smallest tolerance limit 10 = maximum tolerance limit

Now the measured values of each weld are compared with the determined reference values. If the deviation between measured values and determined reference values is larger than the admissible tolerance, an **error message** is displayed and the "Error" LED blinks. The stud welder is then locked until acknowledging the error message with the "LIFT" key

Error messages BMS-10P

Text	Description
Voltage spike	Arc voltage too high
Voltage curve	Arc voltage does not correspond to reference values
Current curve	Flow of the current does not correspond to reference values
Volt.integral	Max. arc voltage does not correspond to reference values
Dp.tm.too hgh	Drop time of gun is higher than reference values
Dp.tm.too low	Drop time of gun is lower than reference values

6.5.2 Subsequent collection or completion of reference values

Depending on the quality and condition of workpieces (rust, forging scales, oil residues), the measuring results of the individual welds are subject to a considerable variance. It might occur e.g. that even perfect welds are reported as defective. This is due to the fact that not enough reference welds have been carried out. For this reason, the stud welder offers two possibilities to collect additional reference values at any time:

1. Select again operation mode "MEAS", this time however using option "Store as measured values" by pressing "Arrow left" key. This enables carrying out further reference welds, which are added to the existing reference welds.
2. If a weld is reported as defective in operating mode "OP", reset the locked stud welder using the "ENTER" key instead of the "LIFT" key. The following message appears on the display:

```
Store as measured    || Do not store
values Arrow left    || Arrow right
```

The values of this weld can be stored as reference values for all further welds using option "Store as measured values" by pressing "Arrow left" key or deleted by pressing "Arrow right" key.

6.6 Special functions

The following additional special functions can be selected with the BMS-10P stud welder:

	<p>NOTE Only select the special functions when you are already familiar with the basic functions of the stud welder.</p>
---	---

The stud welder must be switched off to call up special functions. To call up the respective special functions, certain key combinations must be pressed and kept pressed while switching the stud welder on. For terminating the special function, switch off the stud welder with the main switch.

Now the stud welder can be set into operation again.

The following special functions are available:

6.6.1 Special function "Deleting RAM"

This special function serves as "RESET function" for the stud welder e.g. for eliminating errors or when initiating the stud welder for the first time. All settings and programs in the random access memory (RAM) are deleted.

	<p>NOTE In this process, all your personal user programs are deleted as well. These programs must be entered again. When using the quality control, new reference values have to be determined.</p>
---	--

For deleting the random access memory, please proceed as follows:

- Simultaneously press function keys "Arrow up", "Arrow down", "Arrow right" and "Arrow left" and keep them pressed.
- Switch on stud welder with main switch.

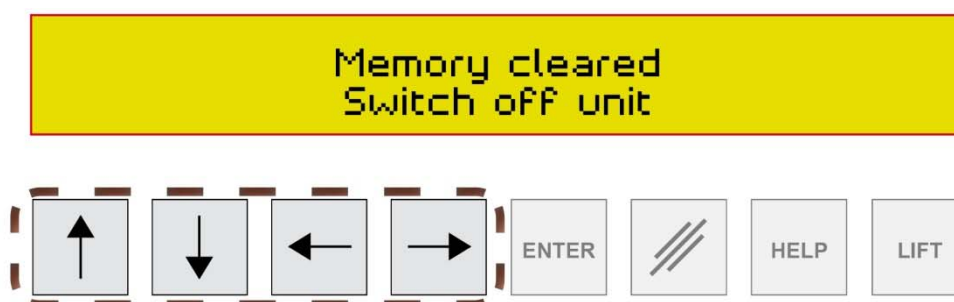

Switch off the stud welder with main switch and switch on again.
The stud welder is now operative.

6.6.2 Special functions - "Extended submenu"

Various parameters can be adapted via this submenu, which is especially helpful when e.g. using an external control system.

To access the submenu, the following procedures are necessary:

- Simultaneously press function keys "Arrow up" and "Arrow down" and keep them pressed.
- Switch on stud welder with main switch.

```

Trg.Del   aut.Id lift Res-Err. Batt. Rdy
  0       on   0   0       2   off
  
```



Parameter	Description	Range	Default value
Trg.Del.	Trigger delay. Start of the welding process via the trigger key or CNC interface is delayed.	0 – 2000 ms	0
aut.Id.	Automatic deactivation of the automatic stud reload process.	on - off	on
Lift	Extension of lift time. Here you can prolong the specified "Lift time" prior to the welding process.	0 – 2000 ms	0
Res-Err.	Automatic error reset. Here you can set a time after which the error signal will be deleted automatically. When setting "0", the error signal won't be automatically deleted.	0 – 2000 ms	0
Batt.	Capacitance switch-over 1 = 33,000 µF 2 = 99,000 µF	1 - 2	2
Rdy.	This function applies to BMK feeders only Rdy = off: The "Ready signal/LED" is displayed after reloading when the blow air time is over. Rdy = on: The "Ready signal/LED" is displayed after reloading when the blow air time is over and a new stud inserted in the feed rail of the stud feeder and is ready to be fired.	on - off	off

6.6.3 Special function "Setting the language. Display of software version number"

This special function serves to select different languages for the display texts and to display the software version number. The languages available are shown in the display.

To select this special function, the following procedures are necessary:

- Simultaneously press the function keys "ENTER" and "DELETE" and keep them pressed.
- Switch on stud welder with main switch.

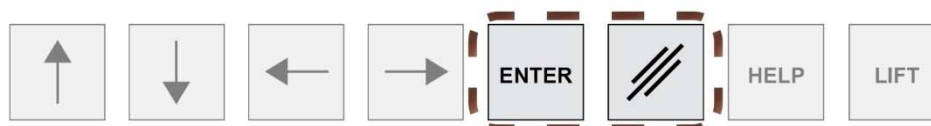

Please follow the instructions shown on the display.

6.6.4 Special function "Setting the feeder times"

With automatic operation, this special function serves to adapt the control to the feeder (parameter 1-4, only with BMK feeder). The type of feeder connected can be set by means of parameter 5.

To call up this special function, please proceed as follows:

- Simultaneously press function keys "Arrow right" and "Arrow left" and keep them pressed.
- Switch on stud welder with main switch.

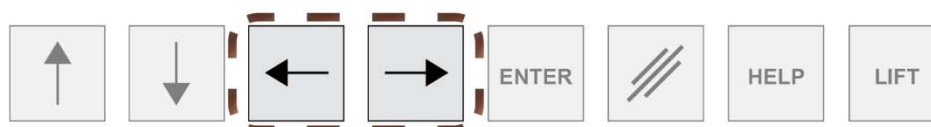

The parameters "Piston", "Ready", "F.lag." and "BI Air" may be selected in 100 ms steps. The parameters may be horizontally selected by using the function keys "Arrow left" and "Arrow right".

Explanation of parameters

Parameter	Description	Range	Default value
Piston	This parameter sets the after-running time of the stud feed blow air for the pushing piston in the welding gun/welding head to press the stud out of the stud chuck. A longer time setting is required when welding e.g. above the head to achieve a trouble-free stud reload.	0 – 2000 ms	0
BIAir	This parameter serves to adjust the delay time of the stud feed blow air after the pushing piston in the welding gun/welding head has moved back. After the set delay time, the stud feed blow air is activated. This is necessary e.g. in the case of a short stud feed hose.	0 – 2000 ms	0
Ready	(only with function UVR BMK) This parameter serves to adjust the waiting period of the hexagonal barrel in the feeding position. Depending on the type of stud, a basic setting between 500 ms and 1000 ms is recommended.	0 – 2000 ms	0
F.lag	(only with function UVR BMK) This parameter serves to adjust the post-vibration period of the feeder to fill the outlet rail when a stud has been brought in blow-off position.	0 – 20.000 ms	0
Feeder	This parameter serves to adjust the feeder type connected. UVRBMS and UVRBMK can be set as feeder types.		

6.6.5 Special function "Setting the feeder operation"

This special function serves as a help for setting the feeder operation. To call up this special function, please proceed as follows:

- Simultaneously press function keys "HELP" and "LIFT" and keep them pressed.
- Switch on stud welder with main switch.



By using the function keys "Arrow left" or "Arrow right" you can move the slider in the feeder's stud escapement to the left or right end position and thereby check the setting. During this process, the operating states of possible existing sensors are displayed as "on" or "off". Use the function key "Arrow up" to activate the blow air and function key "Arrow down" to switch on the feeder. Only the BMK feeders offer this special function as well as the LED displays "Ready" and "Full". For further information, please also refer to the operating instructions of your universal feeder.

6.6.6 Special function "Print protocol"

This special function renders a protocol on the number of welded studs and the errors occurred. The error causes occurred are counted separately i.e. several errors can be recorded for each stud.

To call up this special function, please proceed as follows:

- Simultaneously press the function keys "ENTER" and "LIFT" and keep them pressed.
- Switch on stud welder with main switch.

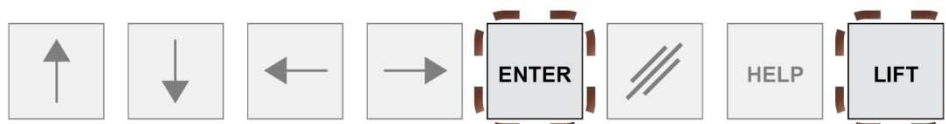

Function "Print protocol"

This function serves to output a protocol via the RS 232 interface at the stud welder's rear onto a printer.

Only printers equipped with a serial interface can be used.

Protocol example:

SOYER BOLZENSCHWEISSGERÄT BMS-10P MESSPROTOKOLL			
Sach Nr.	: _____	Datum	: _____
Los Nr.	: _____	Dat. Fert.	: _____
Los Gr.	: _____	Stichpr. G.	: _____
Platz Nr.	: _____	Name	: _____
<u>Statistikauswertung</u>			
Anzahl der verschweißten Bolzen	:		488
Anzahl fehlerhafte Bolzen	:		13
<u>Fehlerursachen</u>			
Abfallzeit der Pistole grösser als Referenzwerte	:		0
Abfallzeit der Pistole kleiner als Referenzwerte	:		3
Lichtbogenspannung max. entspricht nicht den Referenzwerten	:		1
Lichtbogenspannung entspricht nicht den Referenzwerten	:		9
Lichtbogenstrom entspricht nicht den Referenzwerten	:		2
Spannungsintegral entspricht nicht den Referenzwerten	:		8

Translation:

BMS-10P SOYER STUD WELDER – TEST RECORD

Item no. :	Date :
Lot no. :	Prod. date :
Lot size :	Sampl. size :
Place no.:	Name :

Statistic evaluation

Number of welded studs	: 456
Number of faulty studs	: 13

Error causes

Drop time of gun higher than reference values	: 0
Drop time of gun lower than reference values	: 3
Max. arc voltage does not correspond to reference values	: 1
Arc voltage does not correspond to reference values	: 9
Arc current does not correspond to reference values	: 2
Voltage integral does not correspond to reference values	: 8



Function "Clear protocol"

With this function all digits of the protocol function are set to zero i.e. logging deletes all studs and errors collected so far. This function should only be selected after printing out the protocol.

7 Quality control (stud welding)

7.1 General instructions

Provided the SOYER stud welding system is correctly used and the materials are appropriately selected, the strength of the welding joint (welding zone) will always be stronger than that of the stud or base material.

The following tests are carried out in general practice:

- Visual inspection
- Bend test

Please also refer to the following standard:

DIN EN ISO 14555 *Arc welding of metallic materials* or DVS information sheet • **DVS 0904** *Information on practical application – Arc stud welding*

8 Maintenance

8.1 Important instructions

The stud welder is constructed in such a way that only a minimum of maintenance is required. It should, however, be cleaned by a specialist at regular intervals depending on the environmental conditions at the location of use.

	<p>WARNING</p> <p>The service personnel are required to meet special requirements. Our after-sales service has adequately trained personnel, suitable service equipment and the means to carry out all necessary works.</p>
---	--

8.2 Important instructions for all service works

	<p>DANGER</p> <p><u>Always</u> disconnect the mains cable from the mains supply before starting any repair, maintenance or cleaning work.</p> <p><u>Always</u> disconnect the connecting plug from the mains supply socket before opening the housing of the stud welding system. Only trained and appropriately qualified personnel are allowed to carry out works at the electric mains supply and welding system.</p>
--	---

	<p>NOTE</p> <p>Only use original SOYER[®] spare parts.</p>
---	--

8.3 Cleaning

Cleaning works should be carried out occasionally depending on how soiled the stud welder is.

8.3.1 Detergents for cleaning the housing

Almost any detergent without corrosive or acidic substances is suitable for cleaning purposes. However, please observe the manufacturer's specifications on the detergent you intend to use.

8.4 Replacement of components

Components may only be replaced by trained SOYER personnel. The perfect function of your stud welder can only be guaranteed when original SOYER spare parts are used.

	<p>CAUTION</p> <p>Disconnect the mains cable from the mains supply before replacing any components. Electric and electronic components may only be replaced by the SOYER® customer service or by trained and appropriately qualified personnel.</p>
---	--

	<p>CAUTION</p> <p>Should it become necessary to replace fuses, only use fuses with the specified electrical values. Oversized fuses could either cause defects to the electrical system or a fire.</p>
--	---

	<p>DANGER</p> <p>Disconnect the mains plug from the mains supply when replacing fuses.</p>
---	---

9 Troubleshooting

The following list of errors, their causes and remedies is designed to help you eliminate any trouble immediately on the spot. If you cannot eliminate the trouble, please contact the SOYER customer service responsible for your area or Heinz Soyer Bolzenschweißtechnik GmbH.

	<p>DANGER</p> <p>Before starting any repair, maintenance or cleaning works, <u>always</u> disconnect the mains cable from the socket.</p>
---	--

	<p>CAUTION</p> <p>Electric and electronic components may only be replaced by the SOYER[®] customer service or by trained and appropriately qualified personnel.</p>
---	---

9.1 Malfunctions

Error	Cause → Elimination
System does not weld. No spark formation.	System is not switched on. → Switch system on. LED "Ready" must light up. Digital display lights up.
	Welding points and/or earth connection points at the workpiece are not blank. LED display "Stud on Workpiece" does not light up. → Prepare workpiece or studs accordingly. Grind contact points.
	Welding cable or control cable is not connected properly or is damaged. → Connect cable properly or check for damage. Replace if necessary.
	Wrong mode is set. → Set stud welder to "OP" mode.
No arc although welding system is ready for operation.	Weld studs without ignition tip or centre mark too deep for the ignition tip. → Use weld studs with ignition tip or reduce centre mark.
	Stud is too loose in stud chuck. Press stud chuck together or tighten it.
	Control of stud welder or stud welding gun is defective. → Contact SOYER customer service.
Stud thread scorched.	Stud is too loose in stud chuck. Press stud chuck together or tighten it.
	Stud chuck worn. → Replace stud chuck.

Irregular welding results.	Stud is too loose or not fully inserted into stud chuck until stop. → Insert stud into stud chuck until stop. Replace stud chuck if necessary.
	Inferior-quality weld studs used e.g. with inaccurate dimensions. → Only use SOYER weld studs.
	Welding energy not correctly adjusted. → Adjust welding energy.
	Cable connections too loose. Transition resistances are generated. → Check all cable connections for tight fit.
	Magnetic blowing action. Arc is forced into a certain direction. → Alter fixture of earth clamps, place iron parts on the edges and/or rotate welding gun.
	Irregular operation of stud welding gun or welding head. → Contact SOYER customer service.
Stud not welded with total flange surface, deficient weld joint strength.	Workpiece surface too soiled. → Clean or grind workpiece surface.
	Stud face deformed. → Use new welding studs.
	Welding gun in tilted position. Position welding gun evenly on the workpiece.
	Welding energy is set too low. → Readjust welding energy.
	Poor earth connection. → Check earth cables and ground clamping devices for tight fit.
	Stud projection over stud chuck incorrectly set. → Set distance between stud chuck and stud face to 2 - 3 mm.
Intensive sparking, stud flange almost melted away.	Welding energy is set too high. → Readjust welding energy.
Stud welder switches off.	There are line voltage fluctuations. → Connect stud welder directly to the current distribution.
	Control of stud welder and/or stud welding gun or welding head is defective. → Contact SOYER customer service.
Stud welder indicates malfunction after each weld.	Measured values from other settings have been applied. → Record new measured values.
	Measuring line is defective or not connected. → Check measuring line for proper function and proper connection.
	Tolerance is set too low. → Set correct tolerance.

10 Transport and storage

The stud welder is robustly designed and has a two-piece metal housing with front and rear panel. Owing to electronic components it should be ensured, however, that transport is free from vibrations.

The BMS-10P stud welder has two carrying handles on its top for easy transport and mobile use over short distances.

	<p>NOTE Prevent unauthorized use of the stud welding system by children and unqualified personnel. After long system standstill, we recommend having the stud welding system checked by SOYER® customer servicemen prior to start-up.</p>
---	--

	<p>NOTE The housing of the BMS-10P stud welder corresponds to safety class IP 21. Please observe that this system of protection is not suitable for being operated or transported in the rain.</p>
---	---

11 Terms of warranty

We warrant for this equipment for a period of 12 months in the case of commercial, professional or equivalent use. When repairs are necessary, we guarantee to undertake them in our factory in Etterschlag. Parts subject to wear and tear are excluded.

Any claim to a warranty will be forfeited if damage is caused by improper operation, or if repairs or interferences have been made by unauthorized personnel, or whenever accessories and spare parts have been used which do not match our equipment.

We cannot guarantee the perfect function of the stud welder and the quality of welded joints if welding studs acquired from another company are used.

12 List of standards and guideline

- 2014/35/EU Directive on Low Voltage
- 2014/30/EU Directive on Electromagnetic Compatibility
- EN 60974–1 Arc welding equipment - welding current sources
- EN 60974–10 Arc welding equipment - EMC requirements
- DVS Information Sheet 0901 Arc stud welding of metallic materials
- DVS Information Sheet 0902 Drawn arc stud welding
- DVS Information Sheet 0903 Capacitor discharge stud welding with tip ignition
- DVS Information Sheet 0904 Practical information – Arc stud welding
- EN 14555 Arc welding of metallic materials
- EN 13918 Studs and ceramic ferrules for arc welding
- DGUV Regulation 1 Principles of prevention
- 2006/42/EC Machinery Directive
- EN 12100–1 Safety of machinery – Basic terminology, systems engineering
- EN 12100–2 Safety of machinery – Technical principles and specifications
- EN 60204–1 Electric equipment of machinery, general requirements

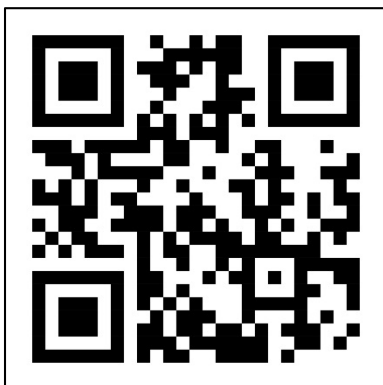

www.soyer.de

Heinz Soyer Bolzenschweißtechnik GmbH

Inninger Straße 14 | 82237 Wörthsee | Tel.: +49 8153 8850 | Fax: +49 8153 8030 | E-mail: info@soyer.de | www.soyer.de